

Maintenance & Operating Instructions

For

Dixon Bayco

AIR INTERLOCK

For Sales and Service Contact

USA:

Dixon Bayco USA
Chestertown, Maryland
Phone: 410-778-2000
Fax: 410-778-4702
Toll Free: 800-355-1991
E-mail: dixonbayco@dixonvalve.com

Canada:

Dixon Group Canada Limited
Mississauga, Ontario
Phone: 905-673-5999
Fax: 905-673-2454
Toll Free: 877-963-4966
E-mail: isales@dixongroupcanada.com

Europe:

Dixon Group Europe Ltd
Preston, England
Phone: +44 (0)1772 323529
Fax: +44 (0)1772 314664
E-mail: enquiries@dixoneurope.co.uk

Asia Pacific:

Dixon (Asia Pacific) Pty Ltd Wingfield,
South Australia
Phone: +61 8 8202 6000
Fax: +61 8 8202 6099
E-mail: enquiries@dixonvalve.com.au

Mexico:

Dixva, S. de R.L. de C.V.
Monterrey, N.L.
Phone: 01-800-00-DIXON (34966)
Fax: 01-81-8354-8197
E-mail: contactenos@dixonvalve.com.mx



The Right Connection®

dixonvalve.com

BILL OF MATERIALS

ITEM NO.	PART NUMBER	DESCRIPTION	MODEL #													KITS													
			5000AI	5000AIV	5000AIR	5000AIST	5000AIHD	5000AIVHD	5000AIRHD	5000AISTHD	5006AIHD	5006AIVHD	5006AIRHD	5006AISTHD	5000AIHK	5000AISK	5000AIRSK	5000AIHDSK	5000AIRHDSK	5006AIHDSK	5006AIRHDSK	5000AIRK1	5000AIHDRK1	5000AIRRK1	5000ST	5000STHD	5000S	5000AIRK2	
1A	341793	BODY AI	1	1	1	1																							
1B	341816	BODY AIHD	-	-	-	-	1	1	1	1	-	-	-	-															
1C	341843	BODY 6AIHD	-	-	-	-	-	-	-	-	1	1	1	1															
2A	391146	PISTON FOR AI	1	1	1	1	-	-	-	-	-	-	-	-															
2B	391148	PISTON FOR AIR			1		-	-	-	-	-	-	-	-															
2C	391847	PISTON FOR AIHD	-	-	-	-	1	1	1	1	-	-	-	-															
2D	391858	PISTON FOR AIRHD	-	-	-	-	-	-	1	-	-	-	-	-															
2E	390922	PISTON FOR 6AIHD	-	-	-	-	-	-	-	-	1	1	-	1															
2F	390923	PISTON FOR 6AIRHD	-	-	-	-	-	-	-	-	-	-	1	-															
3A	391145	END PLUG AI	1	1	1	1	1	-	-	-	-	-	-	-															
3B	391848	END PLUG AIHD	-	-	-	-	1	1	1	1	1	1	1	1															
4A	112024	O-RING AI	3	3	3	3	-	-	-	-	-	-	-	-															
4B	111553	O-RING AIHD	-	-	-	-	3	3	3	3	3	3	3	3															
5	110897	SPRING	1	1	1	1	1	1	1	1	1	1	1	1															
6A	110875	WIPER AI	1	1	1	1	-	-	-	-	-	-	-	-															
6B	112260	WIPER AIHD	-	-	-	-	1	1	1	1	1	1	1	1															
7	110755	RETAINING RING AI	1	1	1	1	-	-	-	-	-	-	-	-															
7	112261	RETAINING RING AIHD	-	-	-	-	1	1	1	1	1	1	1	1															
8	111196	MOUNTING BOLT	2	2	2	2	2	2	2	2	2	2	2	2															
9	110928	LOCK WASHER	2	2	2	2	2	2	2	2	2	2	2	2															
10A	110639	NUT AI	1	1	1	1	-	-	-	-	-	-	-	-															
10B	390909	NUT AIHD	-	-	-	-	1	1	1	1	1	1	1	1															
11A	110804	PLUNGER END AI	1	-	-	-	-	-	-	-	-	-	-	-															
11B	111700	PLUNGER END AI Ø 1.5"	-	-	-	1	-	-	-	-	-	-	-	-															
11C	112258	PLUNGER END AIHD	-	-	-	-	1	-	-	-	-	1	-	-															
11D	400693	PLUNGER END AIHD Ø 1.5"	-	-	-	-	-	-	-	-	1	-	-	-	1														
12	341142	PADDLE PLUNGER	-	1	-	-	-	1	-	-	-	-	1	-															
13A	390673	STUD AI	-	1	-	-	-	-	-	-	-	-	-	-															
13B	390910	STUD AIHD	-	-	-	-	-	1	-	-	-	1	-	-															
14	112370	NYLON LOCKNUT	-	1	-	-	-	1	-	-	-	1	-	-															
15	100202	BALL	-	-	1	-	-	-	-	1	-	-	-	1	-														
16	390104	BEARING	-	-	1	-	-	-	-	1	-	-	-	1	-														
17	390105	ROLLER HEAD CAP	-	-	1	-	-	-	-	1	-	-	-	1	-														

NOT ILLUSTRATED
NOT ILLUSTRATED

AIR INTERLOCK MODELS

- 5000AI - AIR INTERLOCK Ø 1" PLUNGER BUTTON
- 5000AIV - AIR INTERLOCK WITH PADDLE
- 5000AIR - AIR INTERLOCK WITH ROLLER
- 5000AIST - AIR INTERLOCK Ø 1.5" PLUNGER BUTTON
- 5000AIHD - HEAVY DUTY AIR INTERLOCK Ø 1" PLUNGER BUTTON
- 5000AIVHD - HEAVY DUTY AIR INTERLOCK WITH PADDLE
- 5000AIRHD - HEAVY DUTY AIR INTERLOCK WITH ROLLER
- 5000AISTHD - HEAVY DUTY AIR INTERLOCK Ø 1.5" PLUNGER BUTTON
- 5006AIHD - 6 PORT HEAVY DUTY AIR INTERLOCK Ø 1" PLUNGER BUTTON
- 5006AIVHD - 6 PORT HEAVY DUTY AIR INTERLOCK WITH PADDLE
- 5006AIRHD - 6 PORT HEAVY DUTY AIR INTERLOCK WITH ROLLER
- 5006AISTHD - 6 PORT HEAVY DUTY AIR INTERLOCK Ø 1.5" PLUNGER BUTTON

USE RELEVANT REPAIR KIT

- 5000AIHK – REPLACEMENT BOLT AND WASHER
- 5000AISK – SEAL KIT FOR 5000AI / AIV /AIST
- 5000AIRSK - SEAL KIT FOR 5000AIR
- 5000AIHDSK - SEAL KIT FOR 5000AIHD / AIVHD /AISTHD
- 5000AIRHDSK - SEAL KIT FOR 5000AIRHD
- 5006AIHDSK - SEAL KIT FOR 5006AIHD
- 5006AIRHDSK - SEAL KIT FOR 5006AIRHD
- 5000AIRK1 - REPLACEMENT PLUNGER BUTTON FOR 5000AI
- 5000AIHDRK1 - REPLACEMENT PLUNGER BUTTON FOR 5000AIHD / 5006AIHD
- 5000AIRRK1 - REPLACEMENT ROLLER BALL KIT
- 5000ST - REPLACEMENT PLUNGER BUTTON Ø 1.5" FOR 5000AI
- 5000STHD - REPLACEMENT PLUNGER BUTTON Ø 1.5" FOR 5000HD / 5006AIHD
- 5000S – ELECTRONIC SWITCH ATTACHMENT KIT
- 5000AIRK2 – PLUNGER BUTTON AND SLEEVE KIT

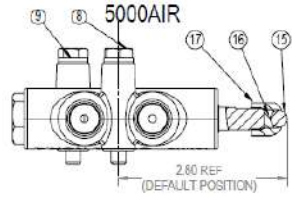
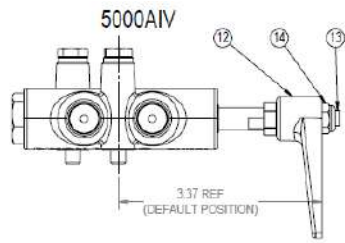
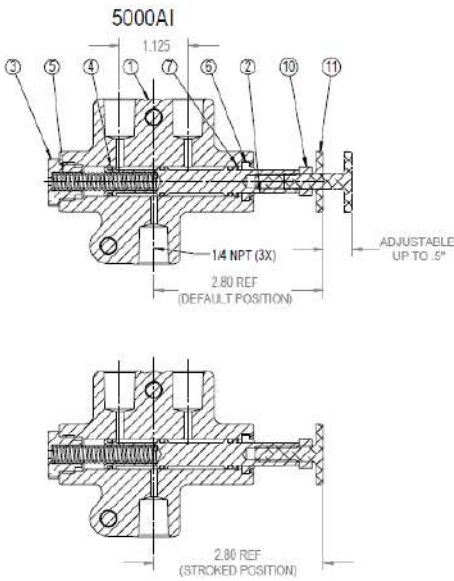

Connection 1 – Example: Mounted on API Valve 5204

Figure 1 – Free Plunger Position

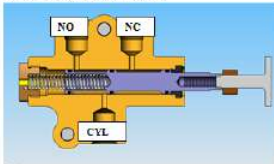

The supply air from the trailer is connected to the NC port. The CYL port is connected to the cylinder to be operated (for example the sequential vapor valve VR6030SQ). The NO port is left open to atmosphere for venting.

Figure 2 – Activated Plunger Position

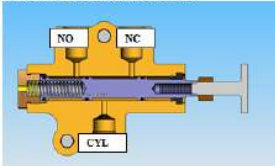

When the plunger is pushed, the exposure of the internal ports switches so that the NC port (supply air in this case) is exposed to the CYL port. This causes air to flow to the sequential vapor valves causing them to open.

Figure 3 – Released Plunger Position

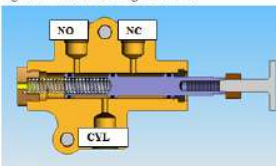

When the plunger is released, the spring returns the spool to its normal position. Now the NC port is blocked (closed) and the CYL port is exposed to the NO port which is open to the atmosphere. This causes the sequential vapor valves to exhaust the air causing them to close again.

Connection 2 – Example: Mounted On Vapor Valve VR4100

Figure 1 – Free Plunger Position

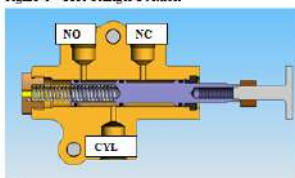

The supply air from the trailer is connected to the NO port. The CYL port is connected to the cylinder to be operated (in this case the truck's air braking system, creating an open flow of air to the brake cylinder). This is in reverse to the above described "connection 1" because truck brakes are off when there is pressure. The NC port is left open to atmosphere for venting.

Figure 2 – Activated Plunger Position

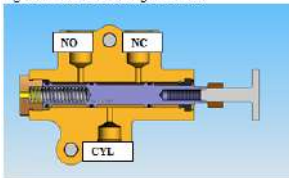

When the plunger is pushed, the exposure of the internal ports switches so that the NC port (open to the atmosphere in this case) is exposed to the CYL port. This causes the brake lines to exhaust air and depressurize, causing the brakes to be set (truck brakes are set with a lack of air pressure). Now the trailer cannot accidentally be driven away from the loading rack while the coupler is still connected to the vapor valve.

Figure 3 – Released Plunger Position

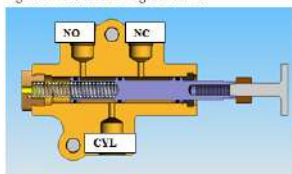

When the plunger is released, the spring returns the spool to its normal position. Now the NO port is exposed to the CYL port (supply air) and the brake lines are pressurized, causing the brakes to unlock. Now the truck can be driven away.

MAINTENANCE AND PARTS REPLACEMENT

DISASSEMBLE

1. Remove the plunger end (11) and nut (10) from the piston.
2. Remove the plug end (3) from the other end and hold the plug end firmly to prevent the spring from ejecting the plug from your hand.
3. Remove the spring (5), then the piston assembly (2 & 4) by pushing the piston toward the end plug side.
4. Remove the wiper (6) & retaining ring if needed

CLEANING, INSPECTION AND REPLACEMENT OF DISASSEMBLED PARTS

Clean thoroughly and visually examine all the parts. Remove any burrs, dirt and sharp edges that could damage the O-rings (4) during reassembly. Thoroughly clean the piston bore to remove any debris. Replace any damaged parts.

ASSEMBLE

1. Before assembling make sure to apply O-ring lubricant to the O-rings.
2. Then assemble the parts together in reverse sequence of disassembly instructions.

CAUTION:

The 5000AIHD & 5006AIHD need to be adjusted when installed. The stem must move far enough for the middle O-ring to fully pass the center air port. If an air leak is detected when the stem is depressed, carefully adjust the stem a little longer to let the O-Ring pass the center port.

For best performance, the internal seals must be kept lubricated. The use of alcohol or other anti freezing compounds in the air lines can have the effect of removing the air interlock lubrication. Continued use of the air interlock without sufficient seal lubrication will shorten the life of the air interlock.

Dixon recommends LUB CL611014OZ from Hi-Tech (lubricant used in production) or Super Lube synthetic grease (NLGI 2) 41160.

DIXON BAYCO WARRANTY:

For Warranty Information, please refer to the inside back cover of the latest Dixon Catalogue.